

# Bolt-A-Bin<sup>®</sup>



[www.ail.ca](http://www.ail.ca)



Atlantic Industries Limited  
**We Support You.**

# Our Commitment

Atlantic Industries Limited (AIL) has built a solid reputation by providing professional support and innovative, high quality corrugated metal products around the world.

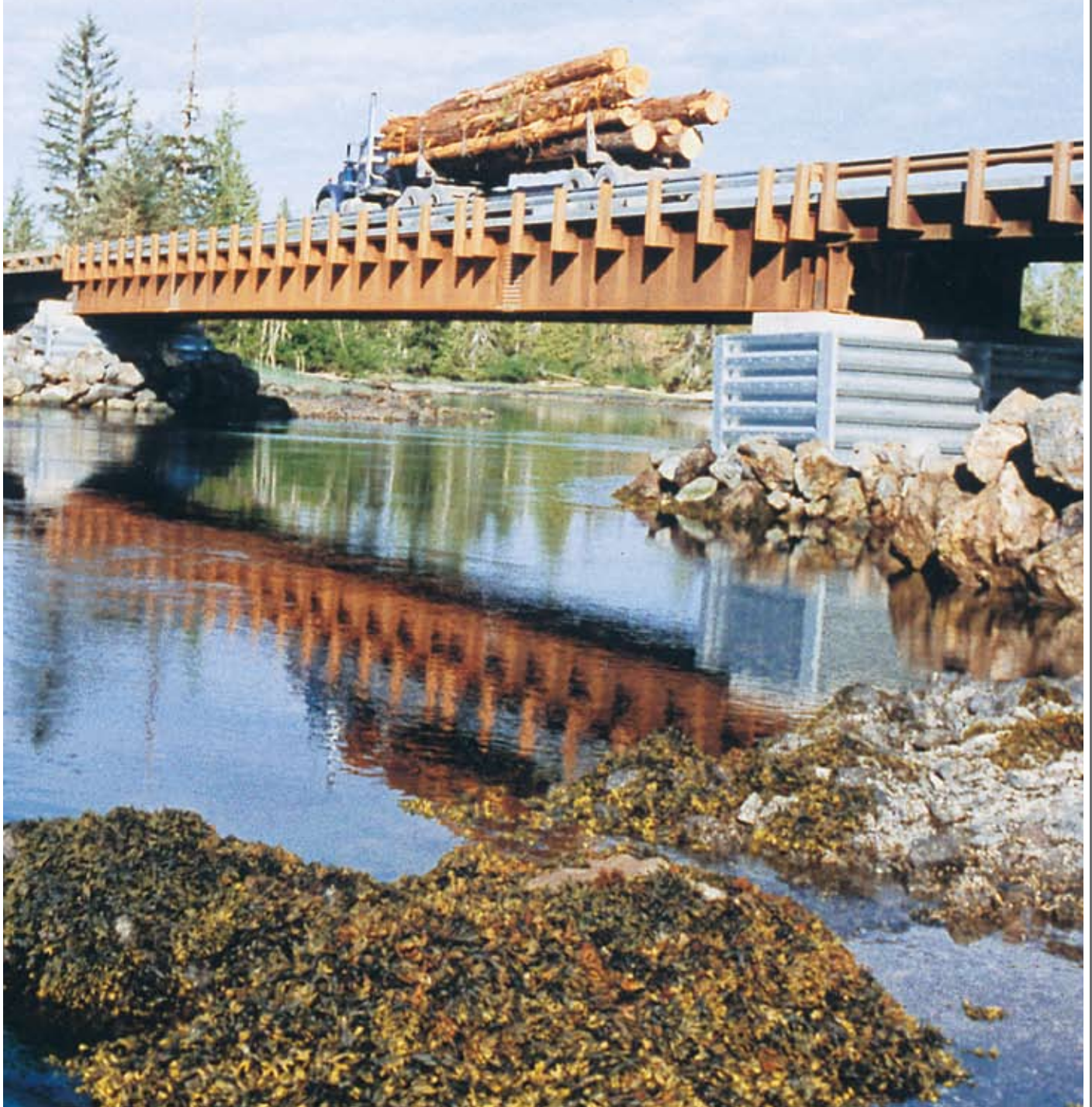

# Bolt-A-Bin®

Bolt-A-Bin® is a cellular metal retaining wall that surrounds a compacted mass of granular material. The cells are formed from strong, corrugated metal components bolted together at the job site and filled. The fill material and metal shell act as a gravity retaining wall to resist sliding and overturning of the earth behind the wall and the surcharged loading on the bin.

## STRONG & FLEXIBLE

The combination of strong corrugated metal members and soil mass provides a sturdy and dependable retaining wall. The flexible design of Bolt-A-Bin® means it can adjust to minor ground movement without cracking or bulging, unlike other types of retaining walls.

## VERSATILE

Bolt-A-Bin® is available in 11 standard depths and numerous heights. Designs can be made to accommodate a variety of projects.

## LIGHT & EASY TO HANDLE

The innovative design of Bolt-A-Bin® can save you money on material and installation. This, coupled with the easy handling of corrugated steel, provides a cost-effective retaining wall. Bolt-A-Bin® can be easily assembled by hand directly at the site.

## ECONOMICAL

This product is cost-effective because of the fast and easy installation, combined with the use of confined material as the gravity retaining wall.

## DURABLE

The standard galvanized coating of Bolt-A-Bin® will provide many years of service.

Some suggested Bolt-A-Bin® applications that can save you time and money and help you finish your project on schedule:

- Reclaiming sloped land areas
- Stabilizing slopes
- Protecting shores and river banks from erosion
- For road widening or grade separation projects
- Providing wing walls for bridges and culverts
- Loading platforms or ramps
- Bridge abutments
- Wharves, loading docks, barricades, cutoff walls, blast walls and more.

Bolt-A-Bin® is ideal for:

- Retaining walls
- Bridge abutments
- Wing Walls



**Economical**  
**Flexible**  
**Easy Installation**

# Bridge Abutments

AIL provides a variety of bridging solutions to meet your most complicated projects. Bolt-A-Bin® bridge abutments are a strong, durable and economical choice for span and portable bridges. Quick assembly and no pile driving or concrete pouring allows for cost effective installation into remote areas.

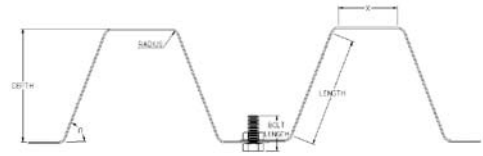

Be sure to consider the design details below (1 - 12) when planning your structure. Your AIL technical representative would be pleased to discuss any or all details with you.

- 1) Backwall - 'A' or 'B'
- 2) Bridge Span
- 3) Number of Lanes
- 4) Live Load
- 5) Superstructure
- 6) Bridge Dead Load
- 7) Bin Height
- 8) Bearing Pad
- 9) 1000 or ?
- 10) Overhang
- 11) Step Required ?
- 12) Bearing Pressure

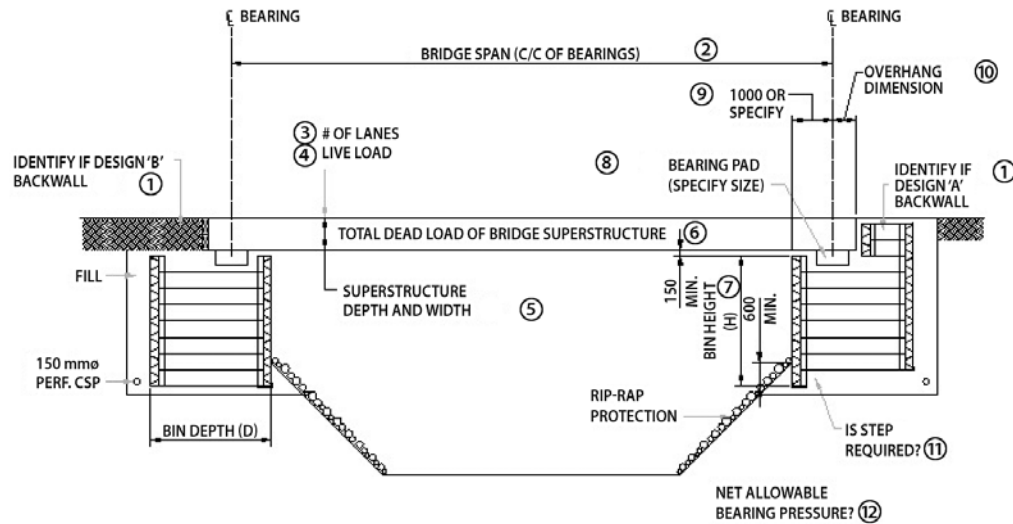

Exploded Isometric

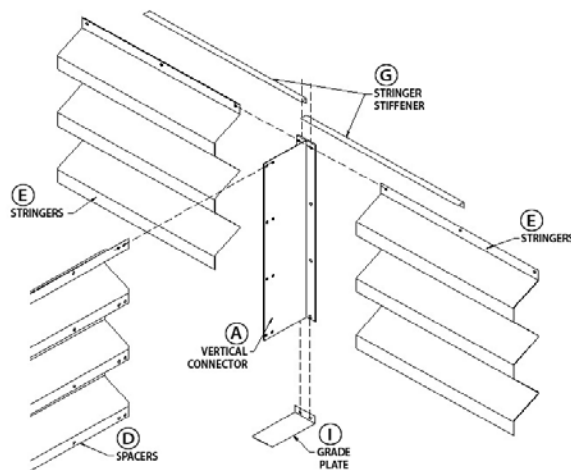

Typical Bridge Abutment Application

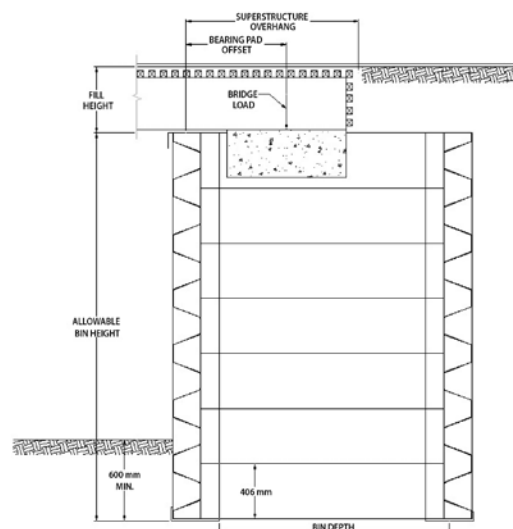

# Retaining Walls

The concept of cellular earth retaining walls dates back to the early 1900s and AIL has improved on the design to provide one of the best retaining walls on the market today.

Forming the metal into the optimum corrugation pattern of Bolt-A-Bin<sup>®</sup> makes it a strong, durable, cost-effective retaining wall offering many distinctive advantages.

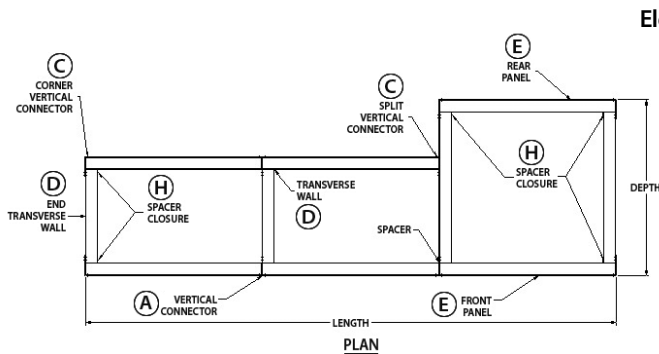
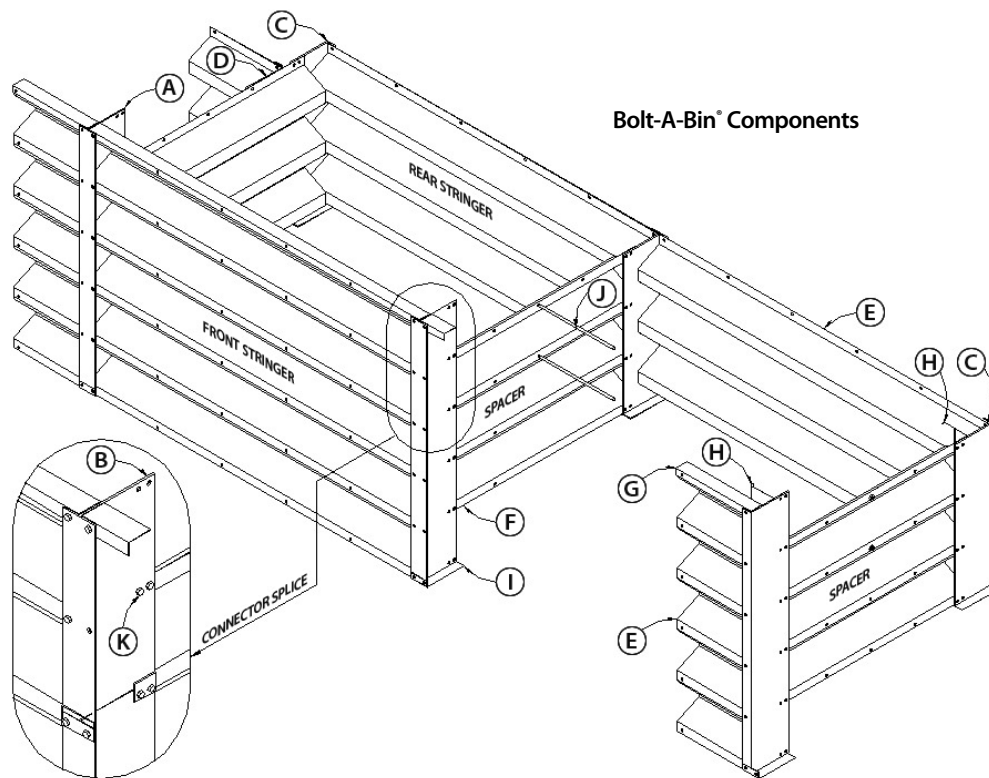

**Elevation**

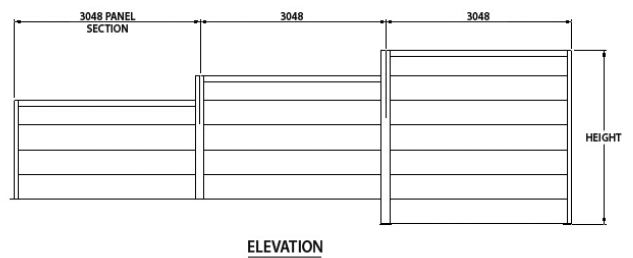

# Retaining Walls

## Standard Bin Combinations

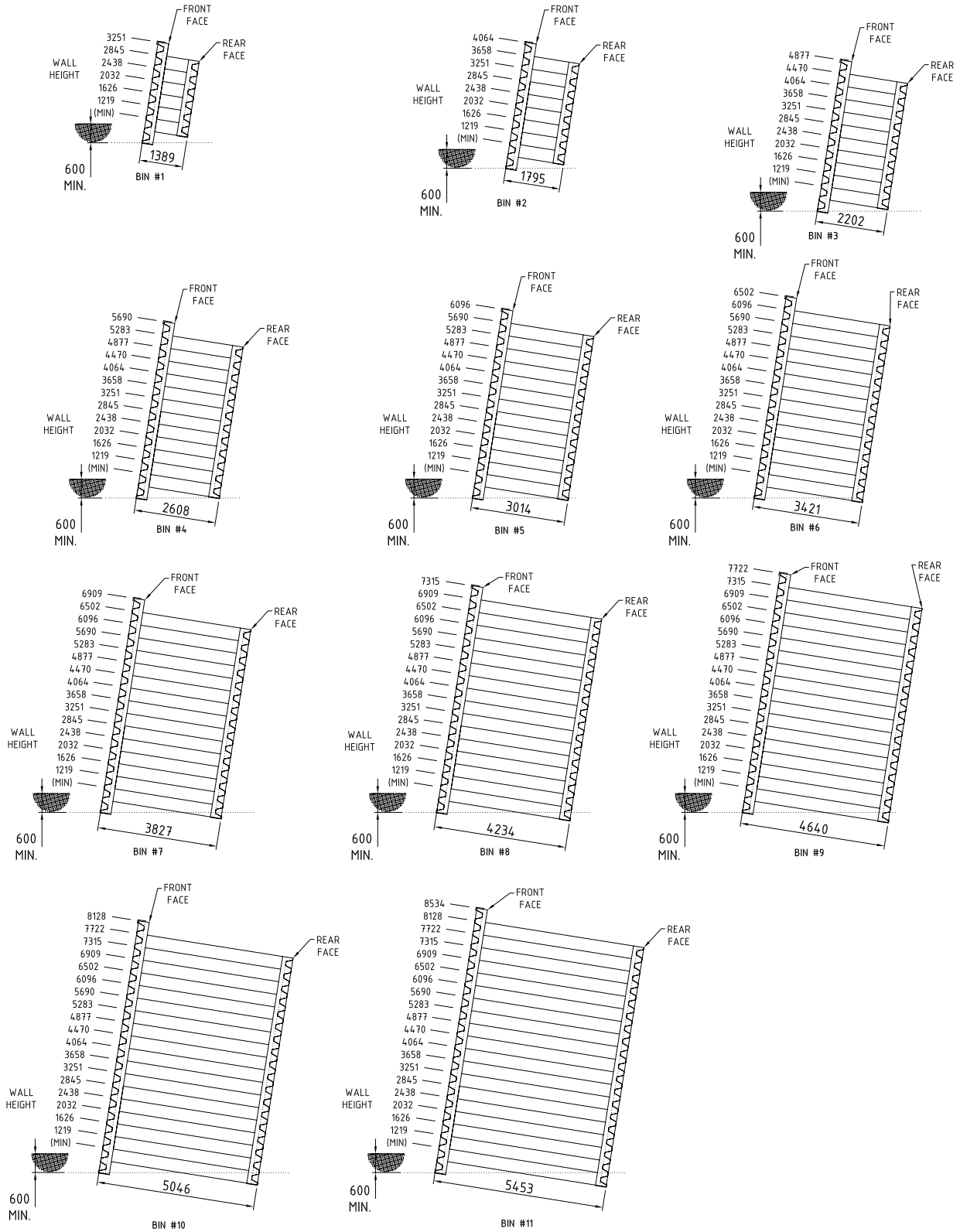



# Design and Installation

Bolt-A-Bin® is AIL's most popular, economical and durable choice for bridge abutments and retaining walls. Our engineers are on call to provide complete project assistance and product support from start to finish.

## CHANGES IN ELEVATION

When a change in elevation is required on a sloped installation, Bolt-A-Bin® can be erected horizontally and shifted in increments of 406 mm to accommodate almost any grade.

## CURVED INSTALLATIONS

Bolt-A-Bin® can be designed to accommodate almost any degree of curvature or change in direction. The most common method of curve adjustment is to shorten the front stringers for concave curves, or the back stringers for convex curves (see curved installation). AIL can assist you with the best method of incorporating Bolt-A-Bin® into your straight or curved installation.

## SITE PREPARATION

A thorough site investigation should be conducted before installing a Bolt-A-Bin® structure. Provisions must be made to allow for slight settling of the vertical corners on rigid, inflexible foundations.

Site preparation should provide a solid base for the structure. It should be good quality material, free from rocks, roots, debris, and organic material. The bed should be well graded, level and in accordance with the elevations of the contract drawings.

## BACKFILL

Close attention must be paid to the design of the backfill requirements because Bolt-A-Bin® structures get their strength from the enclosed mass of earth. A qualified geotechnical engineer should perform a full site investigation and soil analysis.

The backfill material should be clean, free-draining granular material that has good compaction properties and has been approved by a qualified soils engineer. The backfill material should be a maximum of 50 mm and contain no more than 5-10% fines.

The backfill material should be placed in 150 mm to 200 mm layers in the bin and directly behind the bin. The backfill should be compacted to 95 percent Standard Proctor Density. The corrugation area should be filled and carefully compacted by hand to ensure success.

## ASSEMBLY

AIL Bolt-A-Bin® structures may be delivered partially or fully assembled, or may arrive at the site ready for assembly. Every Bolt-A-Bin® comes complete with a detailed plan and set of installation instructions.

Curved Installation

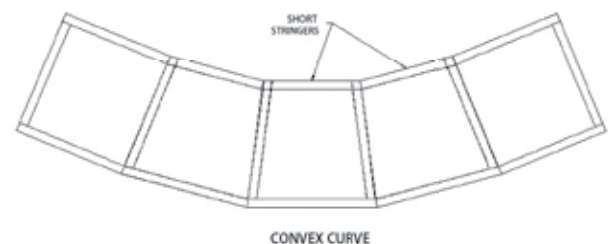
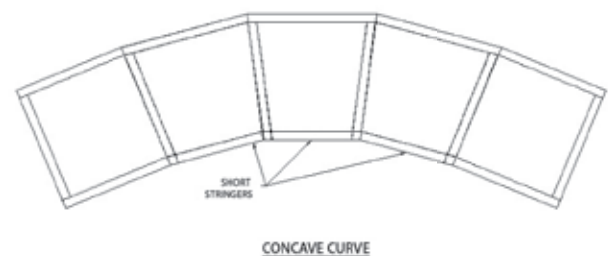

## PRODUCTS AND SERVICES

- Bolt-A-Plate®
- Corrugated Steel Pipe
- Corrugated Steel Pipe Arch
- Corrugated Aluminum Pipe
- Corrugated Aluminum Arch
- Super-Cor® Structures
- Guiderail Systems
- Bolt-A-Bin®
- Hi-Flo Pipe
- Galvanized Spiral Duct
- Window Wells
- Construction Services
- General Fabrication
- Hot Dip Galvanizing
- Geotextiles
- Erosion Control Products
- Water Control Gates
- Gabion Baskets
- Dur-A-Span® Aluminum Structures
- Aluminized Type II
- MSE Retaining Walls
- Atlantic Precast Walls



Atlantic Industries Limited  
**We Support You.**

### OFFICE LOCATIONS

#### Head Office:

Dorchester, NB  
Canada  
Phone: (506) 379-9212  
Fax: (506) 379-1097

#### Western Canada:

Calgary, AB  
Edmonton, AB  
Westlock, AB  
Armstrong, BC  
Vancouver, BC  
Prince George, BC

#### Eastern Canada:

Dorchester, NB  
Deer Lake, NL  
St. John's, NL  
Louiseville, PQ  
Montréal, PQ

#### Central Canada:

Ayr, ON  
Toronto, ON  
London, ON  
Ottawa, ON  
Thunder Bay, ON

#### United States:

Florida  
Colorado  
Utah  
Georgia

The AIL group of companies:



Atlantic Industries Limited



BIGR  
BRIDGE



Atlantic  
Civil Products



T&B  
Structural Systems

FOR ASSISTANCE IN PRICING, ORDERING, OR UNUSUAL INSTALLATIONS,  
CALL TOLL FREE IN NORTH AMERICA: 1 877-AIL-PIPE (1 877-245-7473)

[WWW.AIL.CA](http://WWW.AIL.CA)

