

Dur-A-Span™

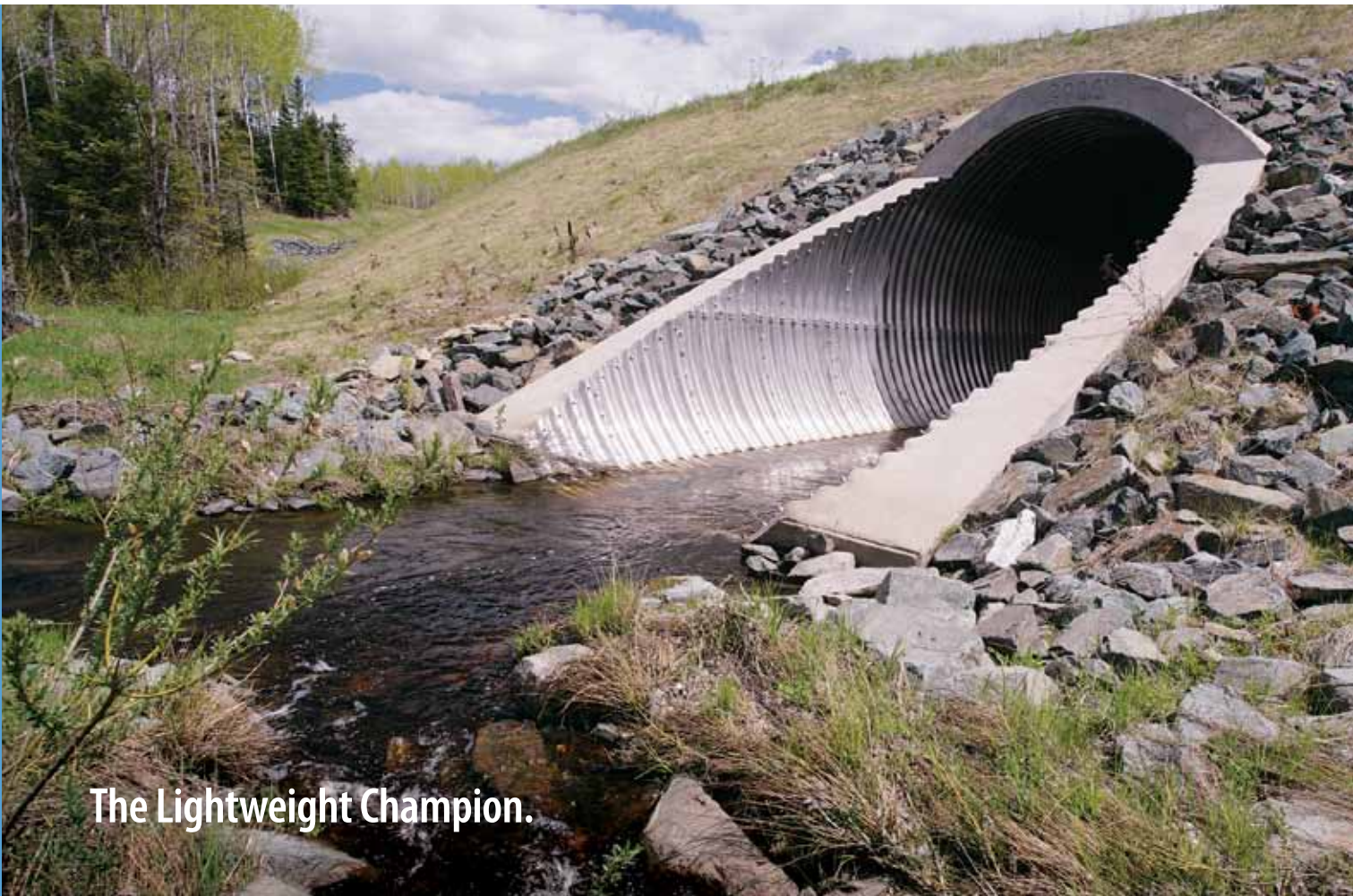

ail.ca

The Lightweight Champion.



Atlantic Industries Limited
We Support You.

Our Commitment

Atlantic Industries Limited (AIL) has built a solid reputation by providing professional support and innovative, high-quality corrugated metal products around the world.

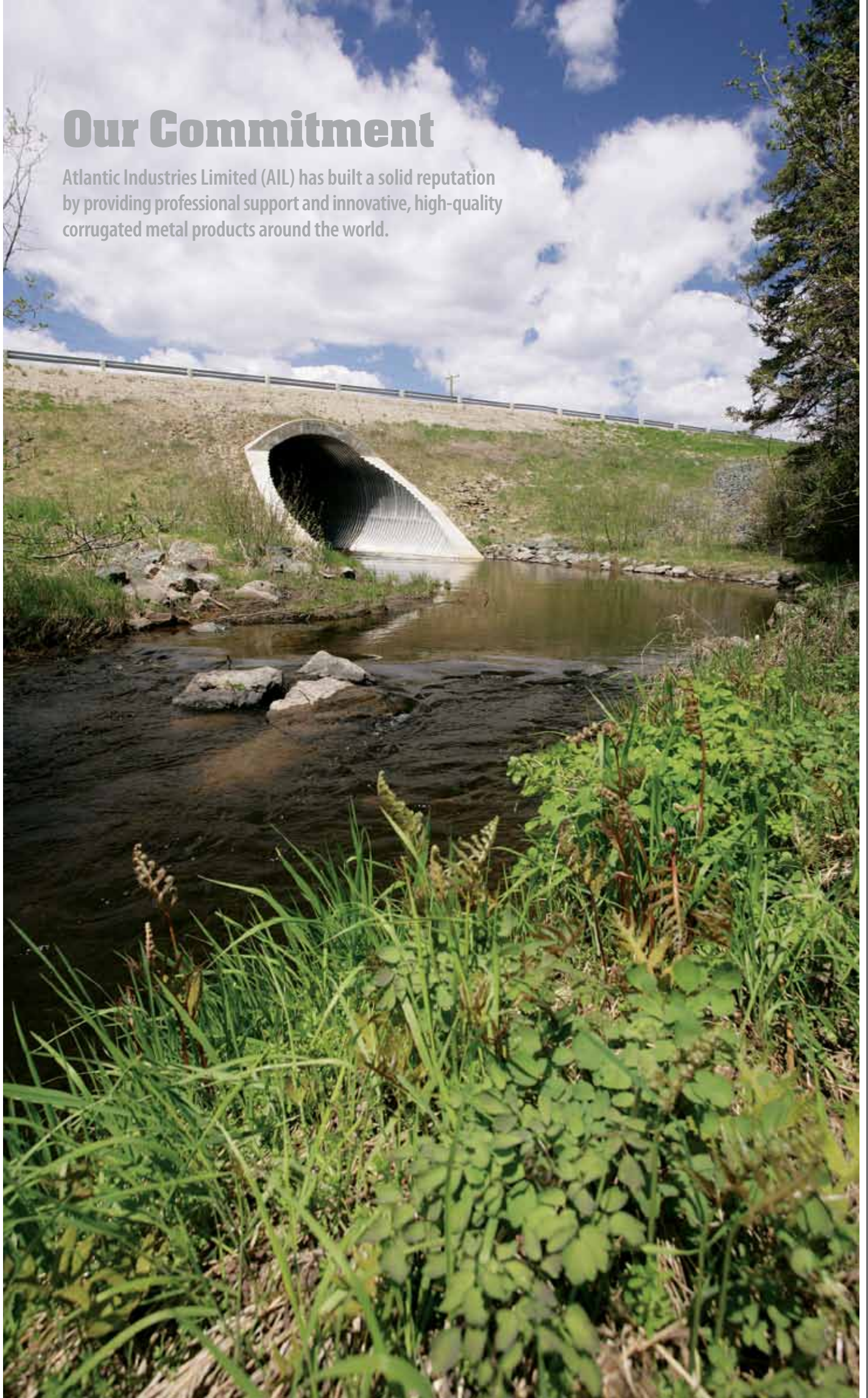

Dur-A-Span™

Lightweight, strong and corrosion/abrasion resistant, All's Dur-A-Span Aluminium Structural Plate has been going the distance in over 1,000 structures worldwide for many years – beating the usual heavyweight contenders, like precast concrete, on overall performance and cost. And now, thanks to our innovative reinforcing rib technology, Dur-A-Span can go even farther (and wider) to outperform all challengers. The proven strength, economy and longevity of Dur-A-Span is ideal for coastal or remote installations.

Corrosion/Abrasion Resistant

Aluminium is well-known for its longer design service life. Proven over many years of wet/dry corrosion/abrasion cycles, its tough, self-healing, oxide surface film reforms immediately if mechanically damaged or corroded in an aggressive environment like salt water.

Lightweight

Dur-A-Span is only 1/50 the weight of reinforced concrete pipe, so it ships for less and installs faster – especially in remote areas. Individual plates and ribs can usually be handled by one worker and bundles can be moved by light-duty lifts.

Easy to Install

Many lightweight Dur-A-Span structures can be shipped assembled to provide obvious installation savings in time and money. If delivered unassembled, the nested components can be made in large sections with up to three different radii in the same plate, reducing the number of joints and assembly time.

Strong

Dur-A-Span is made from the strongest non-heat treatable alloy in common use – alloy 5052. Additional hardware made from alloys 6061 and 6063 also have a proven history of excellent corrosion resistance even in salt-water environments. Their principle magnesium and chromium alloying elements offer high ultimate and yield strengths to create structures that meet AS/NZS 2041: 2010, AASHTO and CHBDC design requirements.

Dur-A-Span is ideal for coastal or remote areas in:

- Stream and river crossings
- Culverts and storm drains
- Conveyor or utility line covers
- Road salt or other storage structures



Dur-A-Span Arch shown with our three types of reinforcement ribs.



All in a day's work and no heavy lifting!

Many Dur-A-Span™ structures can be shipped assembled and be set in position the same day with a medium duty crane or an excavator. In this case, the headwalls were attached on arrival and, at the end of the day, everything was in position and engineered backfilling had begun.



Light, Strong and Durable by Design.

Ever notice how it's only this type of shell that survives the pounding surf? Like the shell, Dur-A-Span™ structures are designed to withstand the harshest corrosive and abrasive coastal environments to outlast all others.



Dur-A-Span versus Concrete

Weight	1/50 the weight of concrete pipe
Installation	Faster, easier to install than concrete, less labour and trucking costs
Site Impact	Minimal with aluminium, lighter (lower cost) equipment, less excavating
Maintenance	Very low, easy to inspect, continuous footings eliminate settling
Durability	Corrosion/abrasion resistant and mechanical joints eliminate separation issues
Versatility	Many size, shape, footing, headwall and wingwall choices
Overall Cost	Installed life cycle cost is substantially lower than concrete
Fish-Friendly Flow	Expansive opening, hydraulic profile design, open bottoms, prevent debris build up and facilitate fish movement.



Dur-A-Span



Traditional RCB

Design

Dur-A-Span corrugation pattern of 230 mm by 64 mm incorporates design theories confirmed by exhaustive field tests. The result is a more efficient and economical structure with a higher section modulus and moment of inertia to increase strength and stiffness. The heat treated assembly bolts are hot-dip galvanized to provide the durability required to withstand even the harshest environments. Aluminium (ASTM F468 Alloy 6061-T6) and stainless steel (ASTM F593 Alloy Group 1, 2 or 3) assembly bolts are also available.

End Treatments

Standard end finishes for Dur-A-Span include square ends, step bevels, skews, partial bevels, and skew bevels. Integrated headwall and wingwall solutions are also available.

Dur-A-Span structures are virtually maintenance-free with a design service life of over 100 years.

Box Culverts

Dur-A-Span™ corrugated aluminium structural plate box culverts combine the structural qualities of rigid box culverts with flexible metal culverts and result in a totally engineered installation. Usually supplied with an open invert, box culverts are an environmentally friendly solution to your construction needs, promoting fish passage throughout the construction period and beyond. Box culverts are used primarily when height is limited and can be used with cover heights as low as 450 mm. A variety of footing options are available.



Full Corrugated Inverts

Full aluminium inverts should be used where scour is a potential problem. They are supplied with flat sheet toe walls.

Footing Pads

Short footing pads are generally the most economical solution for sites where the stream bed is non-erodible. If the stream bed permits, footing pads should be buried a minimum of 450 mm.

Concrete Footings

When concrete footings or concrete inverts are required, Dur-A-Span may be placed in a receiving channel or in a pre-formed slot. AIL can also supply precast concrete footings for faster installation.

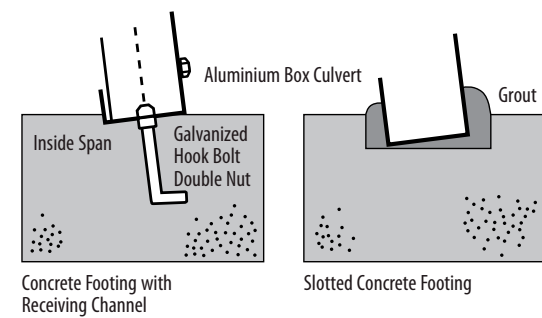

*A minimum soil bearing capacity of 200 KPa is required.

Box Culvert Shell Cross Section

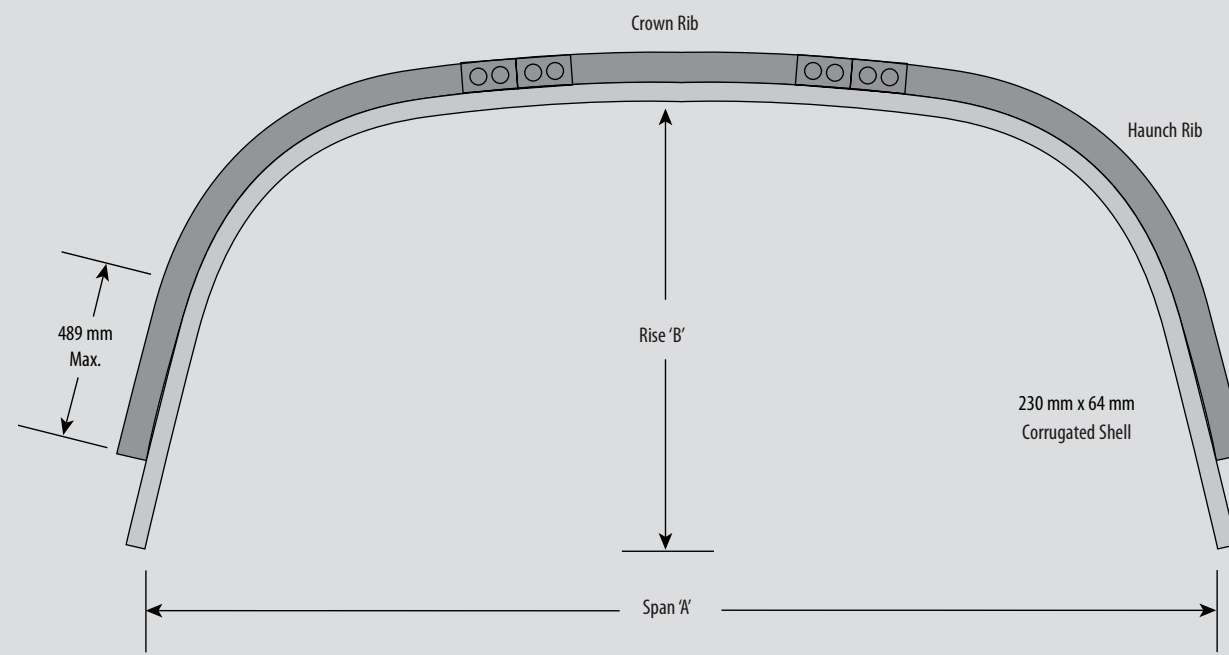

Headwall Packages

The standard headwall package features a headwall and usually two wingwalls. The headwall package results in a finished-looking structure, helps prevent scouring, and assists in channeling water flow. Other attractive headwall options include cast-in-place concrete, precast concrete, mechanically-stabilized earth walls with concrete fascia, gabion baskets or blocks.

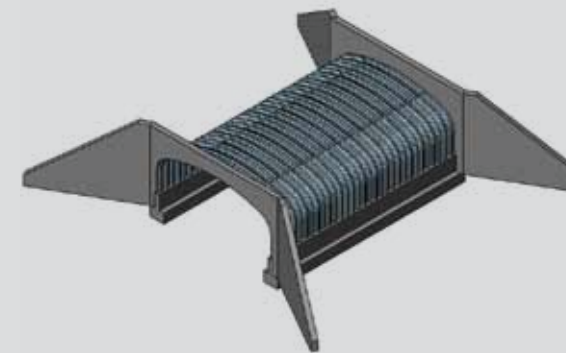

Our new Type X Hat-Shaped Rib allows larger spans.

Our latest rib technology innovation is now taking Dur-A-Span™ to even greater spans and rises than ever before. Our Type X Hat-Shaped Rib's patented, symmetrical profile resists out-of-plane bending and makes it significantly stronger than all other available profiles in both the axial and lateral directions. It easily configures to any haunch radius and can be grout filled for even greater composite strength.

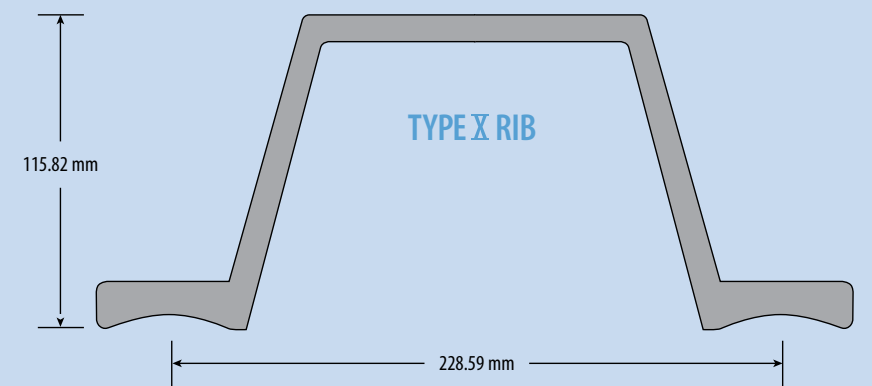

Our Type II and Type IV ribs are ideal for smaller spans.

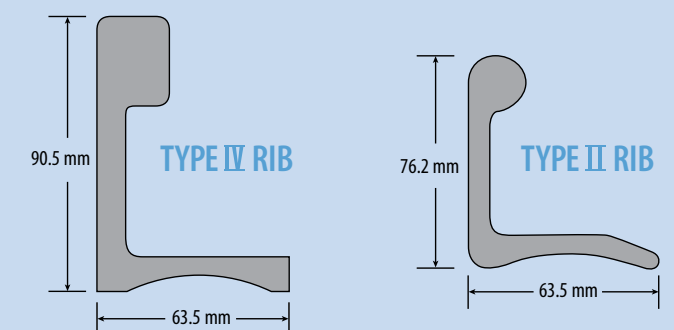

Other Shapes

We create Dur·A·Span™ structures in a wide variety of shapes and configurations to suit many different project needs. If you don't see what you are looking for here, talk to an AIL Technical Representative about our custom sizes and shapes.

Arch

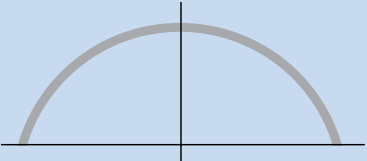

Round

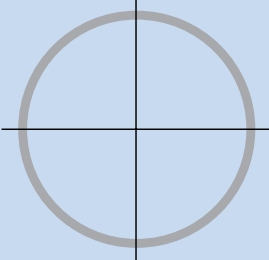

Vertical Ellipse

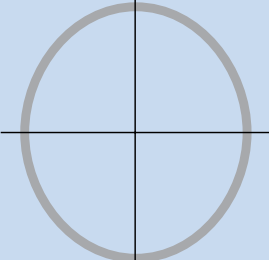

Pipe Arch

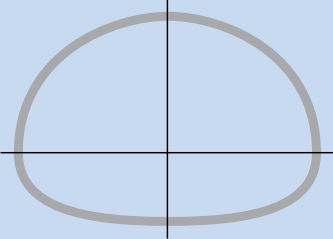

Underpass
(Pedestrian/Animal)

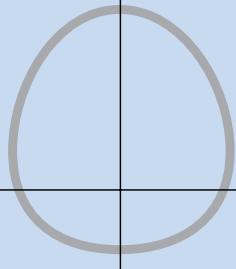

Underpass
(Vehicular)

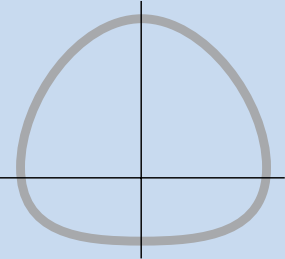

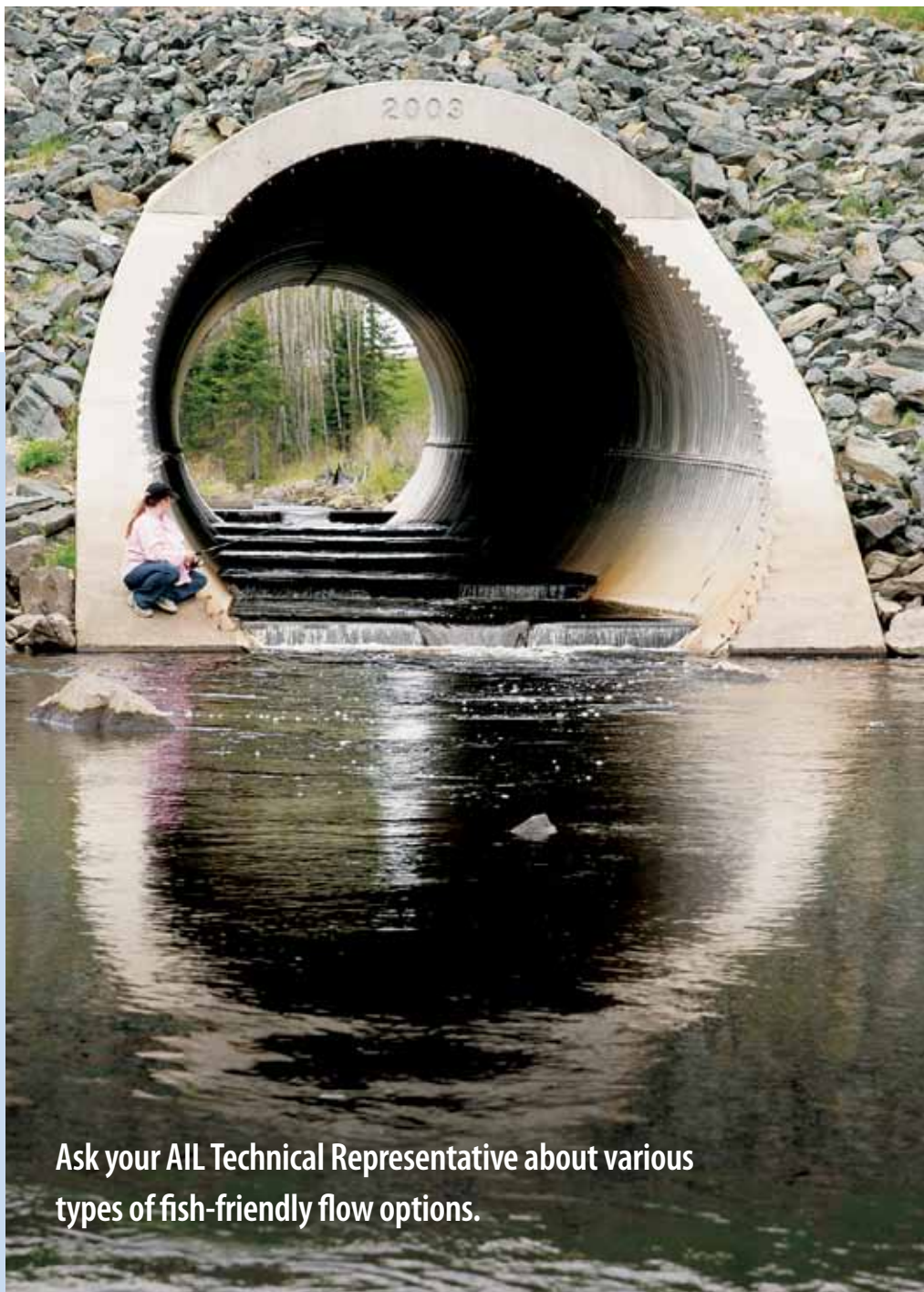

Ask your AIL Technical Representative about various types of fish-friendly flow options.

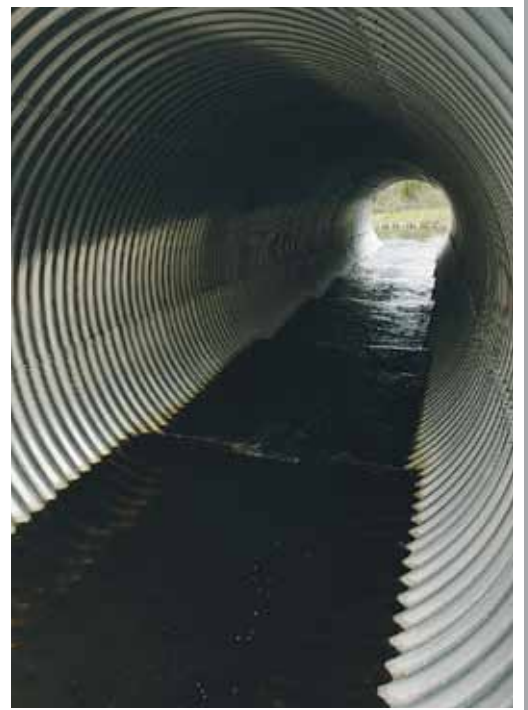

Box Culverts

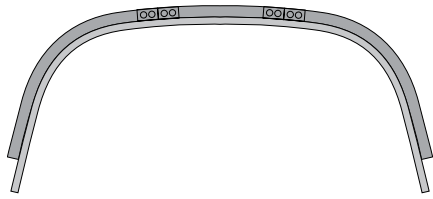

Arch

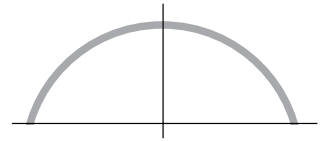

Struct. No.	Span 'A' (mm)	Rise 'B' (mm)	Approx. Area (m ²)
DS-1B	2667	762	1.71
DS-2B	2794	991	2.36
DS-3B	2921	1245	3.03
DS-4B	3048	1473	3.73
DS-5B	3200	1702	4.47
DS-6B	3327	1930	5.24
DS-7B	3454	2184	6.04
DS-8B	3099	813	2.14
DS-9B	3226	1041	2.89
DS-10B	3327	1295	3.67
DS-11B	3454	1524	4.48
DS-12B	3556	1753	5.31
DS-13B	3683	2007	6.17
DS-14B	3785	2235	7.06
DS-15B	3531	864	2.61
DS-16B	3632	1092	3.47
DS-17B	3734	1346	4.36
DS-18B	3835	1575	5.26
DS-19B	3937	1829	6.19
DS-20B	4039	2057	7.14
DS-21B	3962	914	3.14
DS-22B	4064	1168	4.11
DS-23B	4140	1397	5.09
DS-24B	4216	1651	6.09
DS-25B	4293	1880	7.12
DS-26B	4394	991	3.72
DS-27B	4470	1245	4.78
DS-28B	4521	1473	5.87
DS-29B	4597	1727	6.98
DS-30B	4674	1956	8.10
DS-31B	4724	2210	9.23
DS-32B	4801	2438	10.39
DS-33B	4826	1067	4.35
DS-34B	4877	1295	5.53
DS-35B	4928	1549	6.72
DS-36B	4978	1803	7.92
DS-37B	5029	2032	9.13
DS-38B	5080	2286	10.36
DS-39B	5131	2515	11.59
DS-40B	5410	1168	5.05
DS-41B	5537	1397	6.35
DS-42B	5664	1626	7.66
DS-43B	5791	1854	9.02
DS-44B	5918	2108	10.40

Struct. No.	Span 'A' (mm)	Rise 'B' (mm)	Approx. Area (m ²)
DS-45B	6045	2337	11.81
DS-46B	6172	2565	13.25
DS-47B	5817	1270	5.88
DS-48B	5918	1499	7.27
DS-49B	6020	1727	8.70
DS-50B	6121	1981	10.15
DS-51B	6248	2210	11.61
DS-52B	6350	2464	13.12
DS-53B	6452	2692	14.64
DS-54B	6198	1372	6.79
DS-55B	6274	1600	8.29
DS-56B	6375	1854	9.80
DS-57B	6477	2083	11.34
DS-58B	6553	2337	12.91
DS-59B	6655	2565	14.49
DS-60B	6731	2819	16.10
DS-61B	6579	1499	7.79
DS-62B	6655	1727	9.38
DS-63B	6731	1981	11.00
DS-64B	6782	2210	12.63
DS-65B	6858	2464	14.28
DS-66B	6934	2692	15.94
DS-67B	7010	2946	17.63
DS-68B	6934	1626	8.87
DS-69B	7010	1854	10.56
DS-70B	7061	2108	12.27
DS-71B	7112	2337	13.99
DS-72B	7163	2591	15.73
DS-73B	7214	2819	17.48
DS-74B	7264	3073	19.23
DS-75B	7315	1753	10.05
DS-76B	7341	1981	11.85
DS-77B	7391	2235	13.64
DS-78B	7417	2489	15.44
DS-79B	7442	2718	17.25
DS-80B	7493	2972	19.07
DS-81B	7518	3200	20.90
DS-82B	7671	1880	11.33
DS-83B	7671	2134	13.21
DS-84B	7696	2362	15.09
DS-85B	7722	2616	16.96
DS-86B	7722	2870	18.85
DS-87B	7747	3099	20.75

Standard Structure Listing

Span (mm)	Rise (mm)	Approx. Area (m ²)
1524	533	0.60
	686	0.79
	787	0.97
1829	559	0.72
	711	0.95
	838	1.17
	965	1.38
2134	711	1.11
	864	1.37
	991	1.63
	1118	1.89
2438	889	1.58
	1016	1.88
	1270	2.45
2743	889	1.77
	1168	2.44
	1422	3.10
3048	1067	2.35
	1346	3.09
	1575	3.83
3353	1067	2.58
	1372	3.42
	1727	4.63
3658	1245	3.28
	1524	4.18
	1905	5.51
3962	1245	3.54
	1549	4.54
	1803	5.51
	2057	6.46
4267	1422	4.36
	1702	5.43
	1956	6.46
	2210	7.49
4572	1422	4.65
	1727	5.82
	2007	6.94
	2261	8.04
4877	2362	8.59
	1600	5.57
	1880	6.81
	2159	8.01
	2413	9.19
	2515	9.77
5182	1600	5.90
	1905	7.24
	2184	8.52
	2438	9.77
	2692	11.03
5486	1753	6.95
	2057	8.35
	2337	9.71
	2591	11.04
	2718	11.70
5791	1930	8.07
	2235	9.54
	2489	10.96
	2743	12.37
	2870	13.07

Standard Structure Listing

Spans of 12.2 m and greater are available.

Depending upon your application, Box Culvert or Arch spans may be designed in excess of 12.2 m. Please consult with an AIL Technical Representative for further information.

Round and Vertical Ellipse

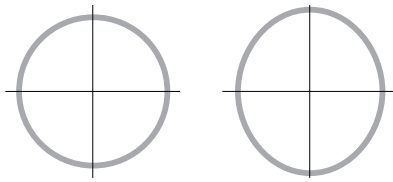

Round Dia. (mm)	Ellipse Dimensions		Approx. Area (m ²)
	Span (mm)	Rise (mm)	
1524	1422	1575	1.77
1676	1575	1727	2.14
1829	1702	1905	2.51
1981	1854	2057	2.97
2134	2007	2235	3.53
2286	2159	2388	4.09
2438	2311	2565	4.65
2591	2464	2718	5.20
2743	2616	2896	5.85
2896	2769	3048	6.60
3048	2921	3226	7.34
3200	3048	3378	8.08
3353	3200	3531	8.83
3505	3353	3708	9.66
3658	3505	3861	10.59
3810	3607	3988	11.52
3962	3759	4166	12.45
4115	3886	4318	13.47
4267	4039	4470	14.49
4420	4191	4648	15.51
4572	4343	4801	16.63
4724	4496	4953	17.74
4877	4623	5131	18.95
5029	4801	5309	20.16
5182	4953	5461	21.46
5334	5080	5639	22.76
5486	5232	5791	24.06
5639	5385	5969	25.46
5791	5512	6121	26.85
5944	5690	6274	28.34

Standard Structure Listing

Pipe Arch

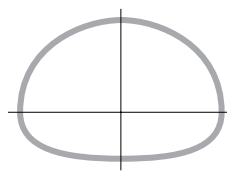

Span (mm)	Rise (mm)	Approx. Area (m ²)
2007	1727	2.75
2108	1753	2.96
2210	1803	3.19
2362	1829	3.42
2464	1854	3.65
2565	1905	3.89
2692	1930	4.13
2819	1956	4.38
2921	1981	4.64
3023	2032	4.90
3124	2057	5.16
3277	2083	5.43
3378	2134	5.70
3480	2159	5.98
3581	2184	6.27
3734	2210	6.55
3835	2261	6.85
3937	2286	7.15
3988	2489	7.71
3988	2540	8.06
4242	2565	8.39
4267	2616	8.75
4242	2870	9.43
4343	2921	9.82
4470	2946	10.21
4547	2997	10.61
4674	3048	11.02
4750	3099	11.44
4902	3150	11.85
4978	3200	12.29

Standard Structure Listing



Relines – infrastructure renewal made easy.

AIL's reline packages can help salvage failing structures and avoid the time, cost, safety and environmental issues inherent in full replacement. Various shapes of Dur-A-Span™ structures can be made for insertion into the existing openings with minimal environmental impact. Grout is placed in the annulus between the structures and new headwall and wingwall packages are available in a variety of finishes. Ask your AIL Technical Representative for more details.

Notes:

Typical cover ranges from 450 mm to 1500 mm. The maximum cover for aluminium box culverts with full inverts and footing pads should not exceed 1.3 m.

N = 244 mm

Dimensions are to inside corrugation crests and are subject to manufacturing tolerances.

Other sizes and custom shapes are available upon request.

Standard Specifications:

Australian Standards AS/NZS 2041: 2010

AASHTO M219M

(corrugated aluminium structural plate)

ASTM B746/B746M

(corrugated aluminium structural plate)

ASTM B209/B209M

(specification of Imperial and Metric plate)

ASTM B789/B789M

(installation of structural plate)

ASTM B790/B790M

(design of aluminium pipe and structural plate)

AASHTO Standard Specifications for Highway Bridges (design)

Canadian Highway Bridge Design Code CAN/CSA-S6-06

CSA G401-2006

Underpass (Vehicular)

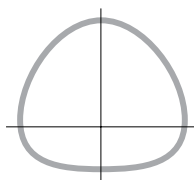

Span (mm)	Rise (mm)	Approx. Area (m ²)
3683	3353	9.85
3912	3404	10.59
3962	3658	11.52
4166	3759	12.36
4267	3937	13.29
4420	4089	14.40
4470	4293	15.33
4699	4394	16.44
4724	4623	17.65
4928	4724	18.58
5029	4877	19.32
5080	4978	19.97

Standard Structure Listing

Underpass (Pedestrian/Animal)

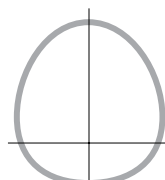

Span (mm)	Rise (mm)	Approx. Area (m ²)
1854	1753	2.60
1905	1854	2.79
1905	1956	2.97
1880	2108	3.16
1930	2210	3.44
1905	2362	3.62
1956	2464	3.90

Standard Structure Listing

PRODUCTS AND SERVICES

- Bolt-A-Plate®
- Corrugated Steel Pipe
- Corrugated Steel Pipe Arch
- Corrugated Aluminium Pipe
- Corrugated Aluminium Arch
- Super•Cor® Structures
- Ultra•Cor® Structures
- Guiderail Systems
- Bolt-A-Bin®
- Hi-Flo Pipe
- Galvanized Spiral Duct
- Window Wells
- Construction Services
- General Fabrication
- Geotextiles
- Erosion Control Products
- Water Control Gates
- Gabion Baskets
- Dur•A•Span® Aluminium Structures
- Aluminized Type II Pipe
- MSE Structural Walls
- Atlantic Structural Walls

THE INFORMATION, SUGGESTED APPLICATIONS AND TABLES IN THIS BROCHURE ARE ACCURATE AND CORRECT TO THE BEST OF OUR KNOWLEDGE, AND ARE INTENDED FOR GENERAL INFORMATION PURPOSES ONLY. THESE GENERAL GUIDELINES ARE NOT INTENDED TO BE RELIED UPON AS FINAL SPECIFICATIONS, AND WE DO NOT GUARANTEE SPECIFIC RESULTS FOR ANY PARTICULAR PURPOSE. WE STRONGLY RECOMMEND CONSULTATION WITH AN ATLANTIC CIVIL PRODUCTS TECHNICAL REPRESENTATIVE BEFORE MAKING ANY DESIGN AND PURCHASING DECISIONS.

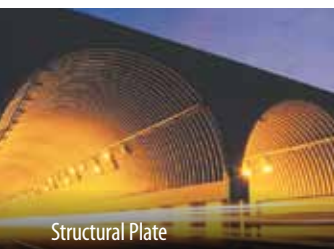

Structural Plate



Wall Systems



Pipe Systems



Prefabricated Bridges



Sound Walls

Call: + 1-506-364-4610, Email: international@ail.ca or Visit: ailgroupofcompanies.com



Atlantic Industries Limited
We Support You.

HEAD OFFICE:
Sackville, NB, Canada

THE AIL GROUP OF COMPANIES



Atlantic Industries Limited



INTERNATIONAL